

NOTES:

- FOR WAVESOLDERING (SOLDER BATH TEMPERATURE 265°C FOR 8 SEC. AND SOLDER PREHEAT 150°C FOR 180 SEC.)
- IP RATING: IP 67
- SEALED TO WITHSTAND PRESSURE UP TO 1,45 PSI FOR 30 MINUTES AFTER HIGH TEMPERATURE EXPOSURE
- METAL SHELL:
 - ZINC DIE CAST; min. 50µm NICKEL PLATING over COPPER
- INSULATORS: PBT GF UL 94 V-0, BLACK
- O-RING: SILICONE PER ASTM D2000 70 SHORE A
- RUBBER GASKET: TPE
- SEALING COMPOUND: EPOXY RESIN UL 94 V-0; BLACK
- CONTACTS: COPPER ALLOY PLATING (SEE PART NO):
 - PLEASE ADD 1 for 30µm HARD GOLD over min. 50µm NICKEL
 - PLEASE ADD 3 for 8µm HARD GOLD over min. 50µm NICKEL
- METAL BRACKETS: ZINC DIE CAST; 300µm COPPER/40-120µm NICKEL/120-200µm TIN
- WASHERS: COPPER ALLOY; 80µm NICKEL
- HEXLOCKING SCREWS: STAINLESS STEEL
- FIXING-PLATE: PBT GF UL 94 V-0; BLACK
- PCB-SNAPS: COPPER ALLOY; min. 200µm TIN over 80µm NICKEL PCB-HOLE: $\varnothing 3.1 \pm 0.1$; PCB THICKNESS 1.6mm
- P.C.B. HOLE DRILLINGS and RECOMMENDED PANEL CUT-OUT ON SHEET 2
- RECOMMENDED TORQUE FOR MOUNTING SCREW 35Ncm (3.1 in.LB) / max.67Ncm (6 in.LB)
- CONNECTOR IS PART MARKED: 15-00219 CONEC ABC

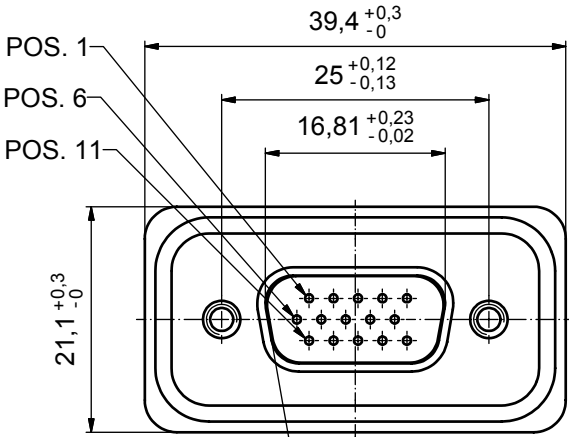

RUBBER GASKET PLACED ON TOP SURFACE OF MALE INSULATOR

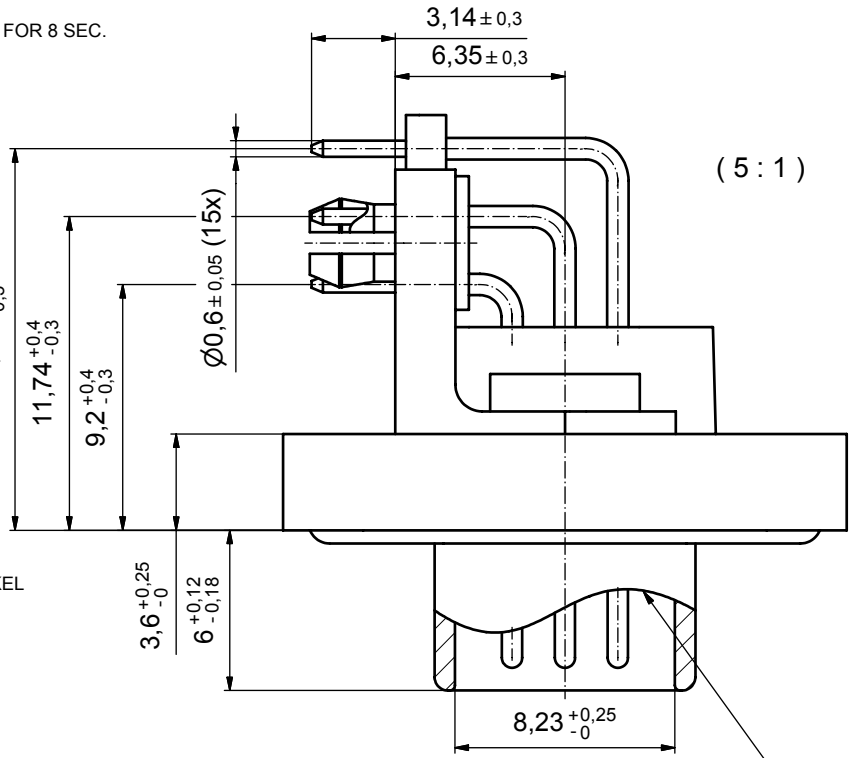
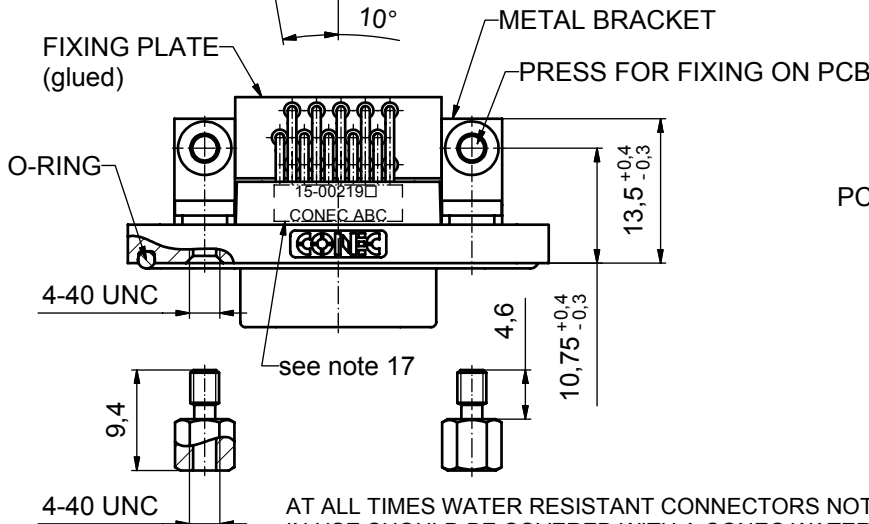
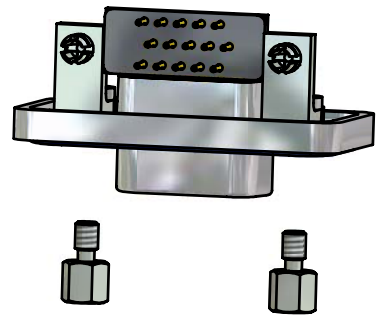

AT ALL TIMES WATER RESISTANT CONNECTORS NOT IN USE SHOULD BE COVERED WITH A CONEC WATER RESISTANT CAP OR WATER TIGHT HOOD.

Directive 2002/95/EC
"RoHS"
Compliant

APPROVAL # FREIGABE # DEBLOCAGE # AUTORIZACION # APPROVAL	
CUSTOMER APPROVAL DATE:	
NAME:	TITLE:
COMPANY NAME:	
APPROVAL # FREIGABE # DEBLOCAGE # AUTORIZACION # APPROVAL	

THIS DRAWING MAY NOT BE COPIED OR REPRODUCED IN ANY WAY, AND MAY NOT BE PASSED ON TO A THIRD PARTY WITHOUT WRITTEN PERMISSION. OWNERSHIP AND COPYRIGHT OF CONEC GmbH DO NOT ALTER CAD DRAWING BY HAND			
rev.	description	date	name
a	Origin		

tolerance			scale: 2:1 (5:1)
dim. in mm			material: see notes
drawn	16.11.09	Schmidt	title: D-SUB HD MALE 90° 15pos. SOLDER PIN ANGLED metal bracket, fixing plate, hexlocking screw, snap
appd.	27.11.09	Fischer	
norm			
d-old			
dwg no:		Inventor 10	DIN-A3
part no:		15K1A498	sh: 1
part no:		15-00219 (see note 9)	



P.C.B. HOLE DRILLINGS

(P.C.B. TOP SIDE)

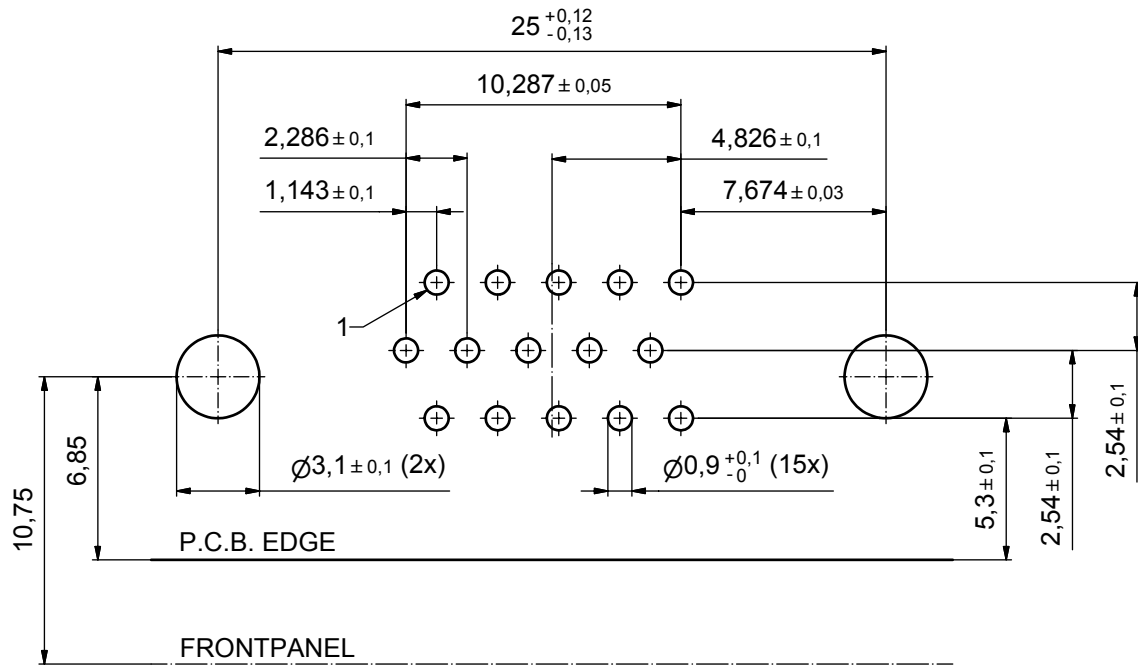

RECOMMENDED PANEL CUT-OUT

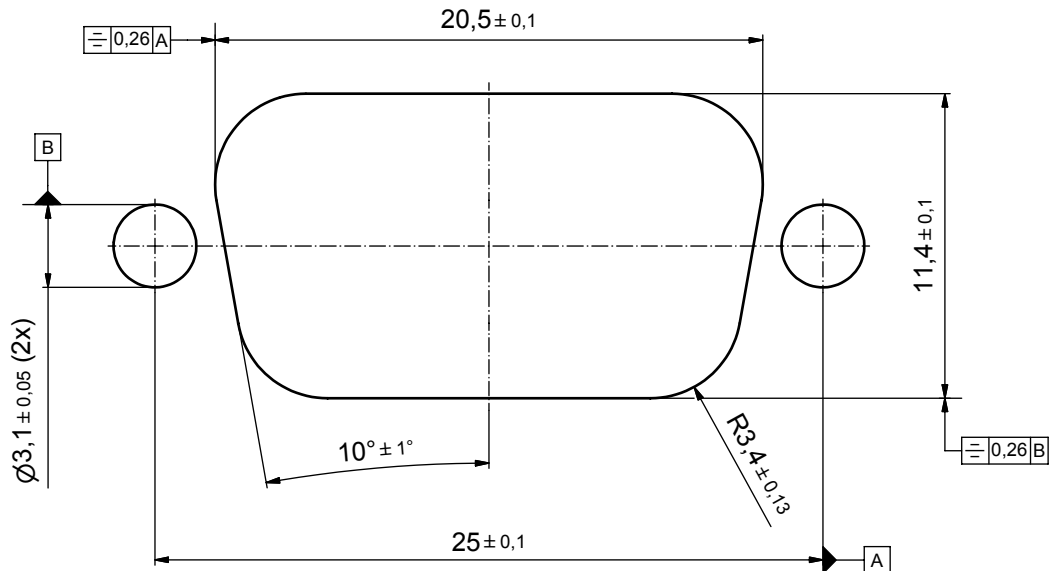

APPROVAL # FREIGABE # DEBLOCAGE # AUTORIZACION # APPROVAL	
CUSTOMER APPROVAL DATE:	
NAME:	TITLE:
COMPANY NAME:	
APPROVAL # FREIGABE # DEBLOCAGE # AUTORIZACION # APPROVAL	

THIS DRAWING MAY NOT BE COPIED OR REPRODUCED IN ANY WAY, AND MAY NOT BE PASSED ON TO A THIRD PARTY WITHOUT WRITTEN PERMISSION. OWNERSHIP AND COPYRIGHT OF CONEC GmbH				tolerance		dim. in mm	scale: 5:1	
DO NOT ALTER CAD DRAWING BY HAND				date			material: see sheet 1	
a	Origin			drawn	16.11.09	Schmidt	title:	
rev.	description	date	name	appd.	27.11.09	Fischer	P.C.B. HOLE DRILLINGS	
				norm			PANEL CUT-OUT	
				d-old			D-SUB Male 15pos. HD Solder pin angled 90°	
						dwg no: Inventor 10		DIN-A3
						15K1A498		sh: 2
						part no: see sheet 1		

